

## **6.3**

# **Water Usage and Care**

### **6.3.4 Water Conscious Building Standards**

**MRIIRS Weblink to SDG 6:**

**<https://mriirs.edu.in/sdg06-clean-water-and-sanitation/>**

### Water Conscious Building Standards

MRIIRS follows all water-conscious building standards to minimize the water use. It has adopted green building norms. Toilets are constructed in such a manner that head loss remain minimum. All overflows are channelized back to sump well. Drinking water and raw water OHT are kept separate. MRIIRS has installed roof top rain water harvesting system in the campus. Also, water saving fixtures and sensors have been installed to taps and toilets.

As evidence in support to 6.3.4 **photo graphs/videos of fittings of tap and sensors**, various OHTs are available. **Roof top rain water harvesting system (RTRWH)** structure has been installed and the detailed have been appended as a consolidated report. The campus is situated in arid region, which stands in water scarcity zone. These practices help in recharging the ground water resource system.

All the data are available in public domain through web site of MRIIRS.

- ✓ [Geotagged Video of drinking water taps installed with sensors](#)
  
- ✓ [Geotagged Video of washroom sink taps installed with sensors](#)

**Report  
on  
Rain Water Harvesting System  
At MRIIRS**

### Introduction:

India is suffering from a severe water crisis the likes of which the country has never seen and millions of lives and livelihoods are under threat. The need of the hour is sustainable, efficient and economic techniques which can tackle water scarcity. One such technology is rain water harvesting. Rainwater harvesting is the collection and storage of rainwater that runs off from the building tops, paved roads and other kinds of open spaces such as parks. The technology has proved itself on varied parameters and has emerged as one of the most important techniques a building can adopt in order to reduce its carbon footprint and enhance its eco friendliness. Manav Rachna being an institution which understands its responsibility of being eco-friendly has successfully installed and introduced the technology in its buildings. The report explains the rain water harvesting system of the institution in a detailed, elaborative, and lucid manner.

**The rain water harvesting system was installed at MRIIRS with the following objectives:**

- ❖ To increase recharge of groundwater by capturing and storing rainwater.
- ❖ To prevent water logging and thus the growth of disease producing bacteria.

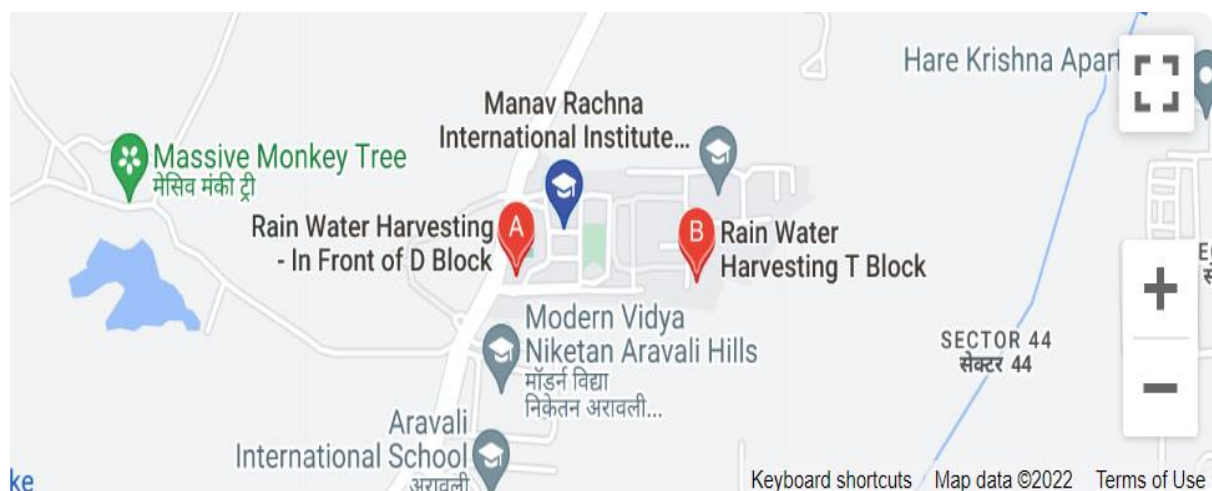

**Location of Rain Water Harvesting System installed at MRIIRS: C Block and T Block**

### Structural details of the rain water harvesting system:

Manav Rachna International Institute of Research and Studies have total area of 18.37 hectare. The potential annual run off of the campus is estimated as 0.044 million cubic meters (MCM). Taking 50% efficiency, the potential run off available for harvesting is 2.2 ham/yr. Thus, the harvesting of runoff water is planned in such a way that it is stored at the nearest possible site where it gets generated. The places of accumulation of run off leading to the water logging in certain areas are indicated in the campus. So, four rainwater harvesting systems have installed in Block A Parking, Block C, near Gate No. 7 of Block T and Block Q of the campus.

**A-block Parking:** The harvested rain water from roof top and paved area of A-Block is entered into the storage tank from where water is entered into six wells of 3-meter diameter and 6-meter depth. The details of this structure are summarised below:

RWH Detail	
<b>Location No.</b>	1
<b>Location Name</b>	A-Block
<b>Installation year</b>	2002
<b>Catchment Area</b>	10,543 m <sup>2</sup>
<b>Dimension</b>	3 m dia 6 m deep

**D-Block Rainwater harvesting System:** The harvested rain water from roof top and paved area is collected in a chamber of 37500 litre capacity. Then the silt free water is passed through filter and brought to the tube well for recharge of ground water. The filter is of 1.5 m<sup>3</sup> volume, filled with boulder, gravel and coarse sand. The filtered water enters the well through slotted pipe. The recharge well is 60 meter deep and is telescopic in structure with 8 inches diameter of 18-meter length and 6 inches diameter of 27-meter length then 6 inches diameter of 12-meter length slotted pipe ended with 3-meter bail plug. The well has been constructed using rotary rig and gravel all through 6 inches diameter tube. Roof water and water from paved area is collected through storm water drain. The floor of the storm water drain is designed to trap silt in it. The details of this structure are summarised in the next table.

RWH Detail	
<b>Location No.</b>	2
<b>Location Name</b>	C-Block
<b>Installation year</b>	2017
<b>Catchment Area</b>	58,710 m <sup>2</sup>
<b>Dimension</b>	0.203 m dia, 60 m deep

**Gate No. 7 of T-Block Ground Water Recharge:** The harvested rain water from roof top and paved area is made to enter into the recharge shaft of 2-meter diameter and 3-meter depth. The lower 1-meter part is filled with coarse sand to trap silt. The bottom of the shaft has been kept open against the aquifer for facilitating recharge. The over flow of the shaft has been connected with storm water drain. The details of this structure are summarised below:

RWH Detail	
<b>Location No.</b>	3
<b>Location Name</b>	T-Block
<b>Installation year</b>	2006
<b>Catchment Area</b>	57791 m <sup>2</sup>
<b>Dimension</b>	2 m dia, 3 m deep

**Q-Block Parking:** The harvested rain water from roof top and paved area of Q-Block is entered into the storage tank from where water is made to enter into one well of 3-meter diameter and 6-meter depth. The details of this structure are summarised below:

RWH Detail	
<b>Location No.</b>	4
<b>Location Name</b>	Q-Block
<b>Installation year</b>	2006
<b>Catchment Area</b>	56656 m <sup>2</sup>
<b>Dimension</b>	3 m dia 6 m deep

Schematic Diagram of Rainwater Harvesting System at MRIIRS

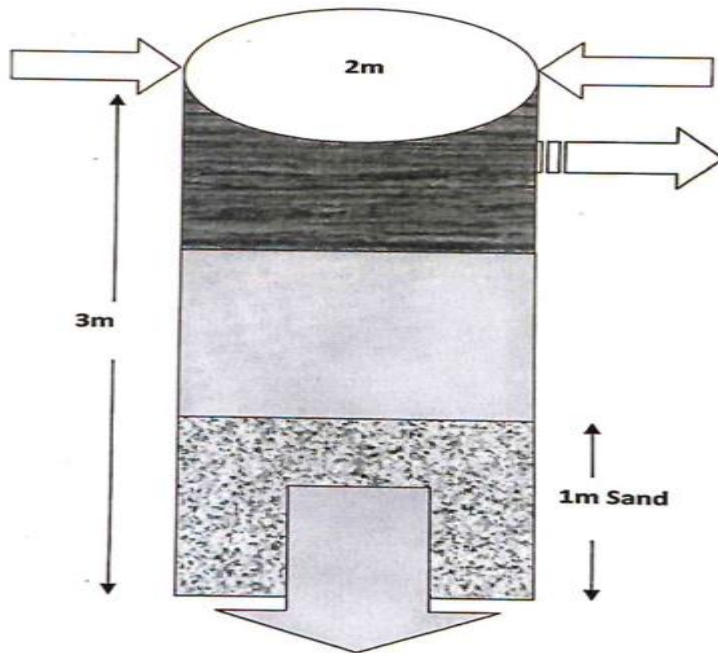

Gate No. 7 of T-Block Ground Water Recharge

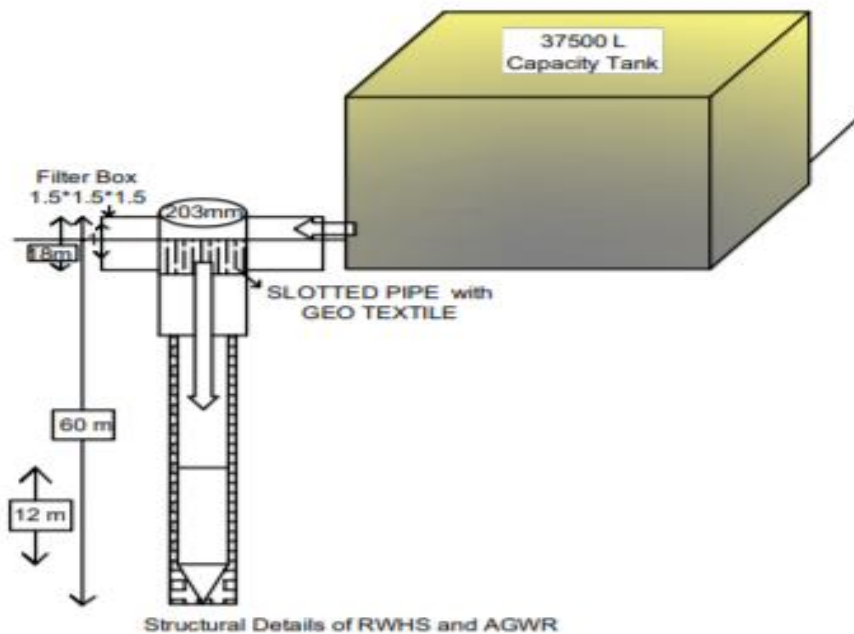

C-Block Rainwater harvesting and artificial ground water recharge

## Water harvesting Capacity of MRIIRS Campus

Total quantity of run off generated from the campus is **4.4375 ham/ year**. It is assumed that 50% of generated run off (i.e. **2.2 ham/ year**) will percolate down into ground water for recharging.

Details of land use and Runoff generation at MRIIRS Campus

Land Use	Zone 1	Zone 2	Zone 3	Total Area	Av. Annual Rainfall	Runoff coefficient	Zone 1	Zone 2	Zone 3	Total Runoff	
	Area						Area Wise Annual Runoff				
Unit	m <sup>2</sup>	m <sup>2</sup>	m <sup>2</sup>	m <sup>2</sup>	m		m <sup>3</sup>	m <sup>3</sup>	m <sup>3</sup>	m <sup>3</sup> /yr	ham/yr
Roof Top	13413	11822	10911	36146	0.523	0.85	5963	5255	4850	16069	1.6069
Paved	20430	18200	7805	46435	0.523	0.7	7479	6663	2857	17000	1.7000
Green Belt	10410	9769	8525	28704	0.523	0.15	817	766	669	2252	0.2252
Open	25000	18000	29415	72415	0.523	0.15	1961	1412	5681	9054	0.9054
<b>Total</b>	<b>69253</b>	<b>57791</b>	<b>56656</b>	<b>183700</b>	<b>0.523</b>	<b>-</b>	<b>16220</b>	<b>14097</b>	<b>14058</b>	<b>44375</b>	<b>4.4375</b>

The geotagged pictures of rain water harvesting structures at various locations have been appended as **Annexure I**.



## **Geotagged Pictures of Rain Water Harvesting System At MRIIRS**

<b>S. No</b>	<b>Relevant documents</b>
1	Rain Water Harvesting Specifications - A Block
2	Rain Water Harvesting A Block
3	Rain Water Harvesting Specifications - C Block
4	Rain Water Harvesting Ground Water Recharge Well - C Block
5	Rain Water Harvesting Specifications - T Block near Gate No 7
6	Rain Water Harvesting Ground Water Recharge Shaft - T Block near Gate No 7
7	Rain Water Harvesting Q Block with specifications



**Latitude: 28.45058212757408,  
Longitude: 77.28267778824198**

**Rain Water Harvesting Specifications A Block**

**Latitude: 28.45058212757408, Longitude: 77.28267778824198  
28°27'02.1"N 77°16'57.6"E**

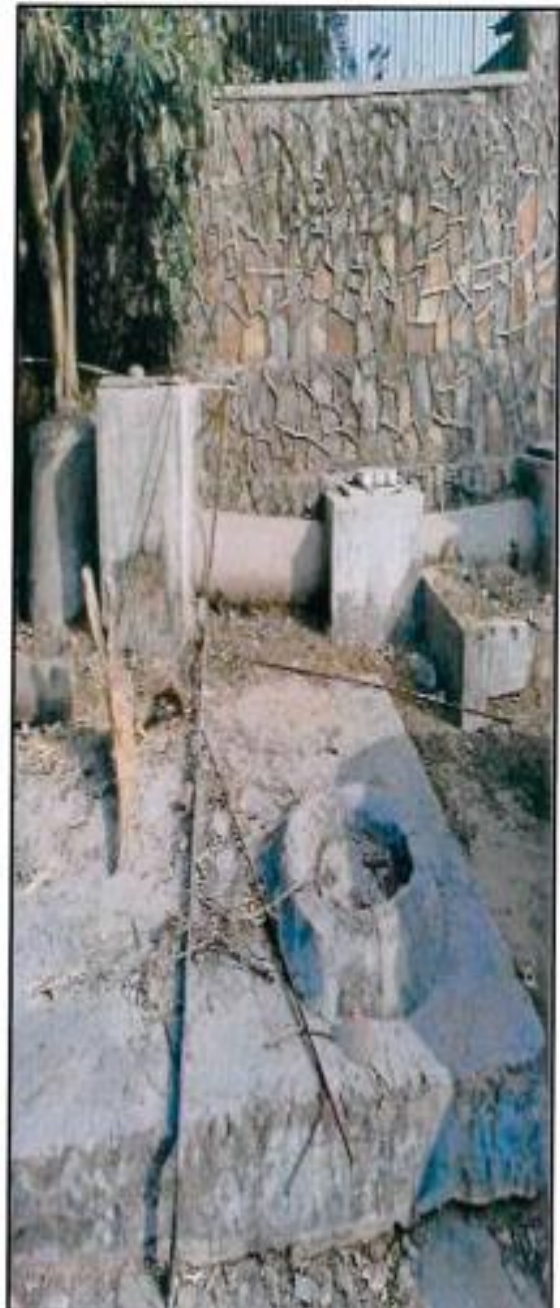

**Rain Water Harvesting A, Block**

**Latitude: 28.45043372846215, Longitude: 77.28271728071604**  
**28°27'01.6"N 77°16'57.8"E**



**Rain Water Harvesting Specifications C Block**

Latitude: 28.449646652682453, Longitude: 77.28266095157997  
28°26'58.7"N 77°16'57.6"E



**Rain Water Harvesting Ground Water Recharge Well C Block**

Latitude: 28.449680103517967, Longitude: 77.2826622628365  
28°26'58.9"N 77°16'57.6"E



**Rain Water Harvesting Specifications-T Block near Gate No 7**

Latitude: 28.449571332093207, Longitude:77.28677887093396  
28°26'58.5"N 77°17'12.4"E



**Rain Water Harvesting Ground Water Recharge Shaft T Block**

**Latitude: 28.449561886511788, Longitude: 77.28678960011572**  
**28°26'58.4"N 77°17'12.4"E**



**Rain Water Harvesting Q Block**

Latitude: 28.450383620880505, Longitude: 77.28761107057075  
28°27'01.4"N 77°17'15.4"E





# Rain Water Harvesting & Artificial Recharge of Groundwater in Campus of MREI



The Manav Rachna Educational Institute campus is having an area of 18.37ha. The potential annual run off of the Campus is estimated as 0.044MCM. The harvesting of runoff water is planned in such a way that water should be stored at the nearest possible site where it generates. The zone wise runoff generation that may be considered for harvesting of the runoff. Two RWH &AR structures were constructed in the campus taking the advantage of morphology of the campus. These structures are described here.

## 1. Structural Details of Recharge shaft

Harvested rain water of roof top and paved area is diverted to a recharge shaft of 1 m dia and 2m depth. The lower 1m part is filled with coarse sand to trap silt. The bottom of the shaft kept open against the aquifer for facilitating recharge. The over flow of the shaft is connected with storm water drain. Annual maintenance is carried out.

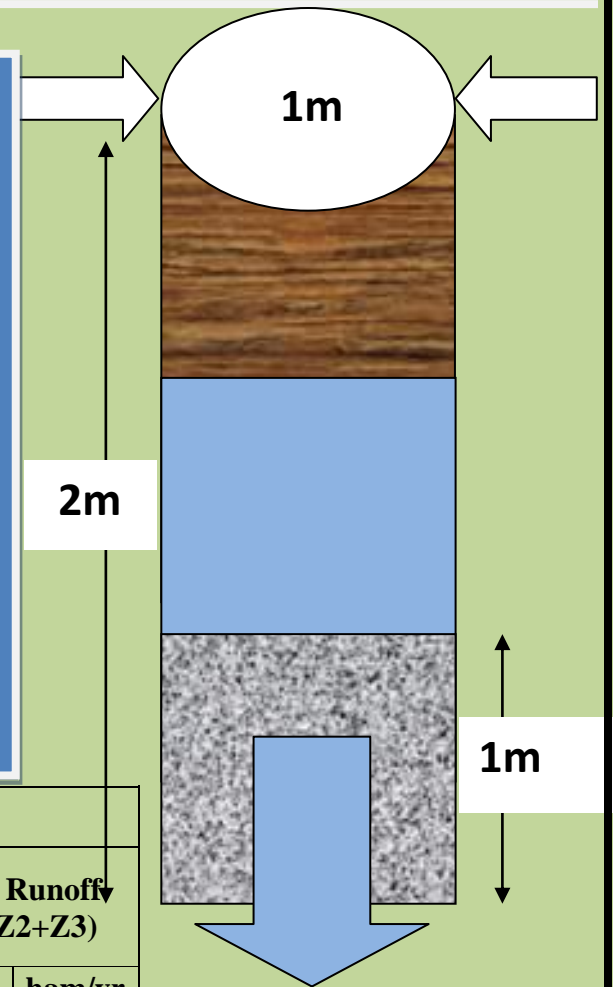

## Details of land use and generation of runoff at MREI campus

Land Use	Zone 1	Zone 2	Zone 3	Total Area	Av annual Rainfall	Runoff Coefficient	Zone 1	Zone 2	Zone 3	Total Runoff (Z1+Z2+Z3)	
	Area						Area wise annual runoff				
Unit	m <sup>2</sup>	m <sup>2</sup>	m <sup>2</sup>	m <sup>2</sup>	m		m <sup>3</sup>	m <sup>3</sup>	m <sup>3</sup>	m <sup>3</sup> /yr	ham/yr
Roof Top	13413	11822	10911	36146	0.523	0.85	5963	5255	4850	16069	1.6069
Paved	20430	18200	7805	46435	0.523	0.7	7479	6663	2857	17000	1.7000
Green belt	10410	9769	8525	28704	0.523	0.15	817	766	669	2252	0.22515
Open	25000	18000	29415	72415	0.523	0.15	1961	1412	5681	9054	0.9054
<b>Campus</b>	<b>69253</b>	<b>57791</b>	<b>56656</b>	<b>183700</b>	<b>0.523</b>	<b>-</b>	<b>16220</b>	<b>14097</b>	<b>14058</b>	<b>44374</b>	<b>4.4375</b>

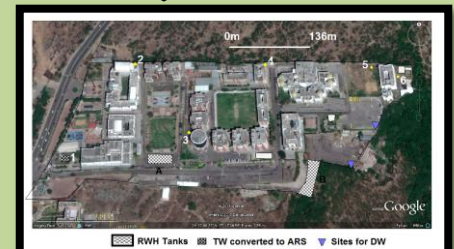

## 2. RAIN WATER HARVESTING AND ARTIFICIAL GROUNDWATER RECHARGE THROUGH ABANDON TUBE WELL

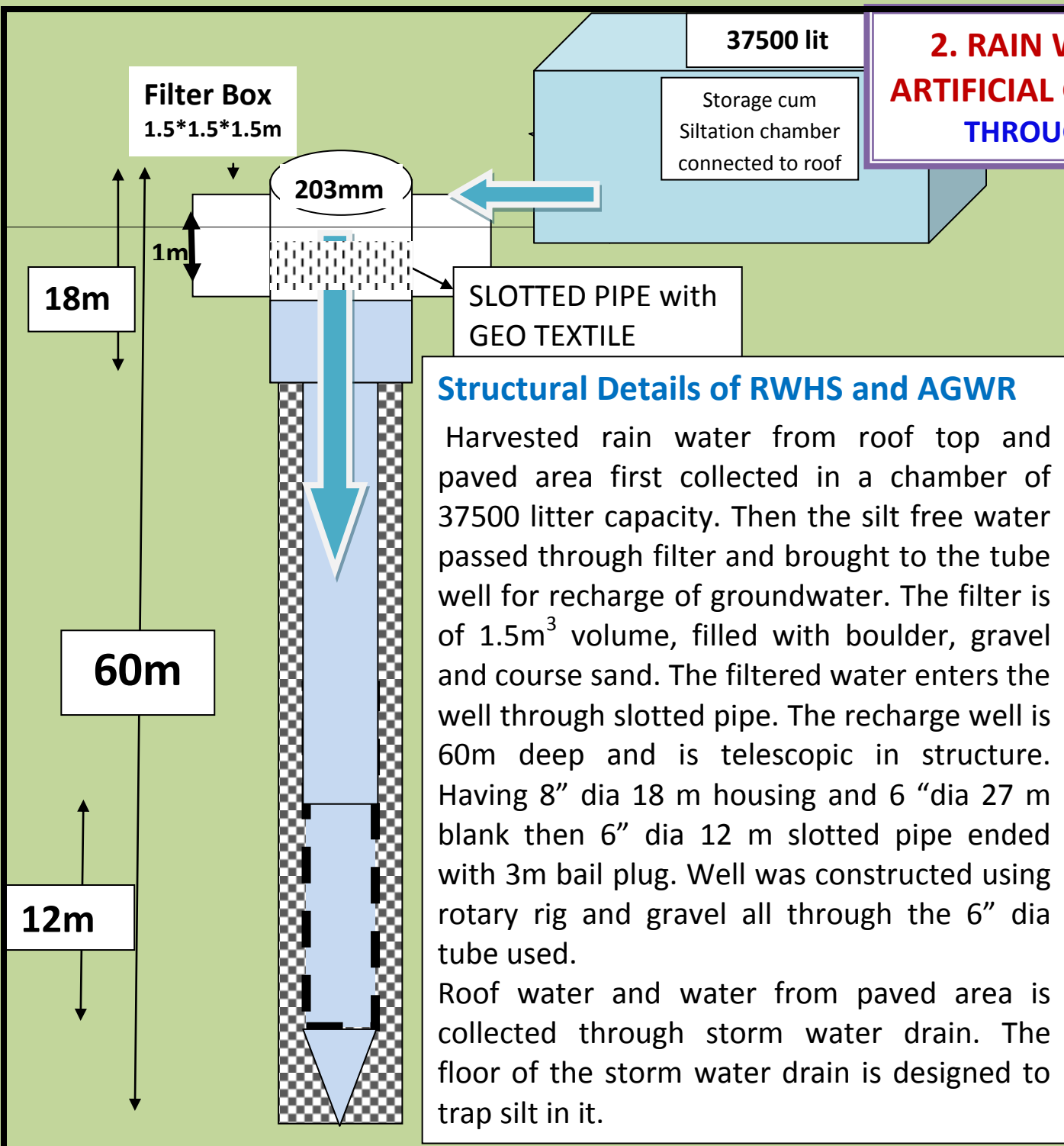

### Structural Details of RWHS and AGWR

Harvested rain water from roof top and paved area first collected in a chamber of 37500 litter capacity. Then the silt free water passed through filter and brought to the tube well for recharge of groundwater. The filter is of 1.5m<sup>3</sup> volume, filled with boulder, gravel and coarse sand. The filtered water enters the well through slotted pipe. The recharge well is 60m deep and is telescopic in structure. Having 8" dia 18 m housing and 6 "dia 27 m blank then 6" dia 12 m slotted pipe ended with 3m bail plug. Well was constructed using rotary rig and gravel all through the 6" dia tube used.

Roof water and water from paved area is collected through storm water drain. The floor of the storm water drain is designed to trap silt in it.

